

Features



XGQ-F washer-extractors have a full spring and shock suspension system that effectively isolates vibration transmission to the floor allowing for installation where the foundation need only support the static weight of a fully loaded machine. The tubular steel frame is a solid structure housing all electrical and control components, and the suspension system that encloses all moving parts.



Inverter with single motor drive is energy efficient, has fewer parts, and provides smooth power at all speeds.



Multi-language color touchscreen control features full programmability of all machine functions including interfacing up to 13 signals to external chemical systems, and displays relevant machine operating data, including a full array of maintenance and productivity reports.



Available with exclusive **Water Droplet** drum design. Art of Convex/Concave for the perfect Clean.

www.sealionamerica.com

Commercial Washer-Extractor



Commercial washer-extractors from Sea-lion combine economy and performance into a reliable, field proven machine design. Features like extra large door openings into baskets with smooth, dimpled perforations highlight the design quality and build craftsmanship put into these machines.



Models available in 25, 50, 80, 100, 130 and 160kg dry load capacity.

Specifications

Machines are certified to ETL C-US standards. Some new models, including existing models that are in the process of being revised, may not be certified at the time of production. Consult factory for available certifications.



6/2022

Intertek



CFQ:22

Description	unit of measure	XGQ-25F	XGQ-50F	XGQ-80F	XGQ-100F	XGQ-130F	XGQ-160F
Rated capacity (dry load)	kg / lb	25 / 60	50 / 110	80 / 175	100 / 225	130 / 285	160 / 350
Inner drum: width x depth	mm	810 x 560	990 x 701	1150 x 843	1240 x 882	1350 x 966	1460 x 1032
Outer drum: width x depth	mm	864 x 618	1054 x 759	1218 x 922	1324 x 953	1434 x 1044	1544 x 1104
Washing/Balance speed	rpm	43/75	40/60	30/60	30/60	30/60	27/55
Medium/High Extract speed	rpm	430/810	375/750	360/700	350/680	310/640	300/630
High Extract G Force	G	297	311	315	320	309	323
Motor power (VFD)	kW	3	4	6.5	7.5	15	22
Electric heater power	kW	22.5	45	---	---	---	---
Steam connection	DN	20	20	25	25	40	40
Hot & Cold Water inlets	DN	25	25	40	40	50	50
Water consumption/load	kg	400	750	1200	1800	1900	2000
Steam consumption/load	kg	20	30	45	50	60	70
Electric consumption (VFD) Electric	kW.h	5	7	---	---	---	---
Electric consumption (VFD) Steam	kW.h	0.8	1	1.6	1.8	2	2.2
Water pressure	MPa	0.2-0.4	0.2-0.4	0.2-0.4	0.2-0.4	0.2-0.4	0.2-0.4
Steam pressure	MPa	0.4-0.6	0.4-0.6	0.4-0.6	0.4-0.6	0.4-0.6	0.4-0.6
Compressed air pressure	MPa	0.4-0.6	0.4-0.6	0.4-0.6	0.4-0.6	0.4-0.6	0.4-0.6
Overall Dimensions (L/W/H)	mm	1355/1190/1585	1550/1353/1755	1945/1600/1930	1982/1718/2020	2245/1850/2075	2310/1915/2130
Weight	kg	1054	1494	2570	2812	4012	4476



SEA-LION



Product details and machinery specifications are based on the latest information available at time of printing. Sea-lion America Company and Jiangsu Sea-lion Machinery Co., Ltd. reserve the right to change prices and specifications without notice.

- Sea-lion America Company
- P.O. Box 1063
- Westbrook, CT 06498
- Phone: (860) 316-5563
- Email: sales@sealionamerica.com

Parameters

Product details and machinery specifications are based on the latest information available at time of printing. Sea-lion America Company and Jiangsu Sea-lion Machinery Co., Ltd. reserve the right to change prices and specifications without notice.

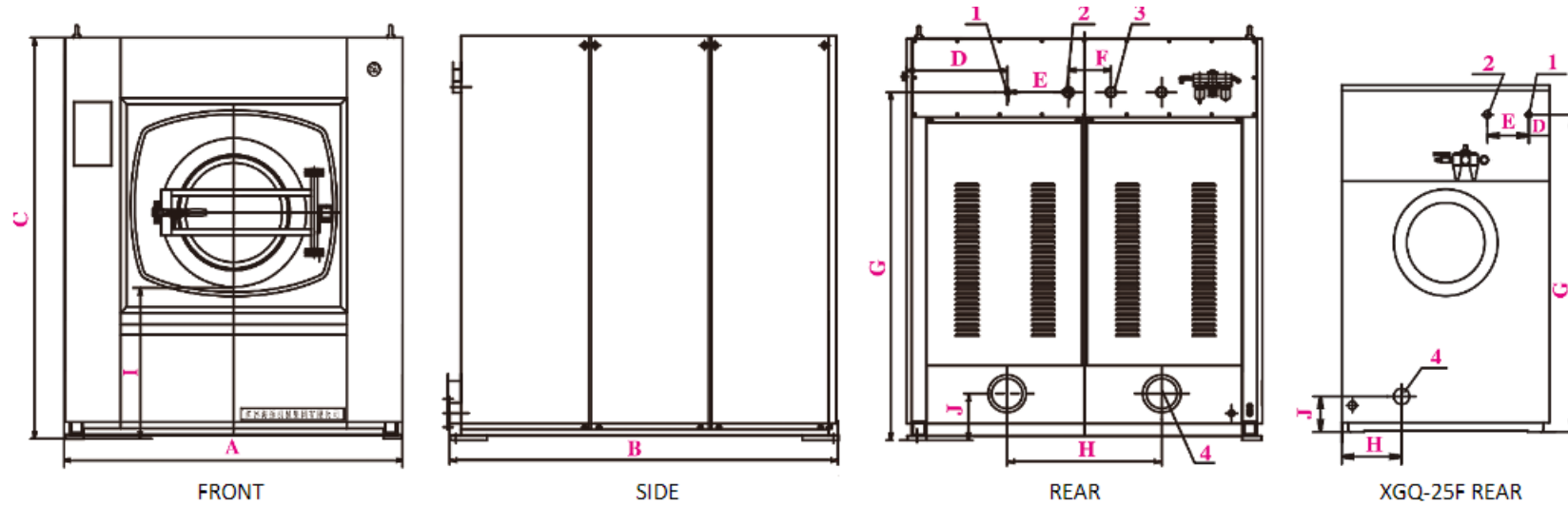

Model	A	B	C	D	E	F	G	H	I	J	steam inlet	cold water	hot water	drain outlet
											1	2	3	4
XGQ-25F	1190	1355	1585	90	317	100	1366	990	671	150	DN20	DN25	DN25	DN100 right
XGQ-50F	1353	1550	1755	340	100	100	1485	680	680	114	DN20	DN25	DN25	2-DN80
XGQ-80F	1600	1945	1930	427	288	200	1610	666	735	205	DN25	DN40	DN40	2-DN125
XGQ-100F	1718	1982	2020	477	288	200	1680	730	735	225	DN25	DN40	DN40	2-DN125
XGQ-130F	1850	2245	2075	420	185	220	1830	950	710	266	DN50	DN50	DN50	2-DN125
XGQ-160F	1915	2310	2130	433	140	220	1906	1016	705	248	DN50	DN50	DN50	2-DN125

Note: The dimension includes the foot, hanging bolt, FLR and emergency buttons etc.



SEA-LION